

GENERAL INFORMATION - FumeOut is an automatic exhaust fan, designed to remove fumes which are normally produced during battery recharge or equalization. Consisting mostly of hydrogen and oxygen, these gases can become explosive if allowed to accumulate in the battery compartment or other enclosed spaces. By drawing these fumes outdoors, FumeOut™ performs an essential safety function.

The FumeOut package consists of a 12 volt DC brushless Exhaust Fan and a Fan Controller. The Controller continuously measures your battery bank voltage, turning on the Fan whenever the voltage becomes high enough to generate fumes during the recharge process. As soon as the battery voltage drops below the point where gassing occurs, the Controller shuts off the Exhaust Fan. Some other features:

FAN STALL ALARM - Whenever the Exhaust Fan is running, the Fan Controller continuously checks the Fan for adequate motor speed. If the motor should stop spinning or fail to start, the Controller will sound an alarm beeper and blink a red LED warning light visible from the front panel.

PURGE TIMER - This function is designed to evacuate any fumes which may accumulate in between periods when the batteries are being recharged. When enabled, the Purge Timer turns on the Exhaust Fan for approximately 5 minutes every 24 hours, regardless of battery voltage.

MULTI-VOLTAGE OPERATION - Thanks to an efficient switching-type voltage regulator, the same Fan can be used on 12, 24 or 48 volt battery banks.

BATTERY DISCONNECTED ALARM - This feature sounds an alarm if the voltage sensing connection between the batteries and the Fan Controller fails.

PROGRAMMABLE SETPOINTS - The Fan Controller is factory-calibrated with a default fan turnon voltage (Von) of 2.33 volts per battery cell, and a turn-off voltage (Voff) of 2.30 volts per battery cell. Depending on whether a 12, 24 or 48 volt battery bank is present, these values will correspond to bank voltages of:

	12 Volt Battery Bank:	24 Volt Battery Bank:	48 Volt Battery Bank:
Fan Turn-On Voltage:	14.0 Volts	28.0 Volts	56.0 Volts
Fan Turn-Off Voltage:	13.8 Volts	27.6 Volts	55.2 Volts

A DIP switch on the Fan Controller circuit board allows these settings to be changed by the user. The turn-on voltage can be set to any value between 2.20 and 2.46 volts per cell, in 32 increments. The turn-off voltage can be set to be either 0.033, 0.066, 0.099 or 0.133 volts per cell below the turn-on setting.

OPERATING INSTRUCTIONS

TO MANUALLY TURN THE FAN ON: Briefly press the **FAN MOTOR OVERRIDE** button. The Fan will start and run continuously, and the green **Fan Motor Running** indicator LED will be flashing. Briefly press the **OVERRIDE** button again to cancel manual Fan operation, restoring the fan to automatic control.

TO PROGRAM A NEW FAN TURN-ON OR TURN-OFF VOLTAGE: Set the DIP switches marked A-E to adjust the turn-on voltage, or set the switches marked X and Y to adjust the turn-off voltage. Consult the chart on the inside back of the enclosure cover for the switch positions that correspond to your desired settings. Note that the turn-off settings are always expressed as fractions of a volt **BELOW** the current turn-on voltage - never above it.

TIP: Although battery gassing typically occurs at around 2.4 volts per cell, it can vary somewhat with plate chemistry, temperature, battery condition and Controller calibration. For this reason, it is important to select a fan turn-on voltage which is low enough to ensure adequate compartment ventilation under worst-case conditions. The Controller's default Von value of 2.33 volts/cell was chosen to meet this requirement, even though it might be lower than your actual gassing voltage. When programming in a new turn-on voltage, it is always smart to err on the low side.

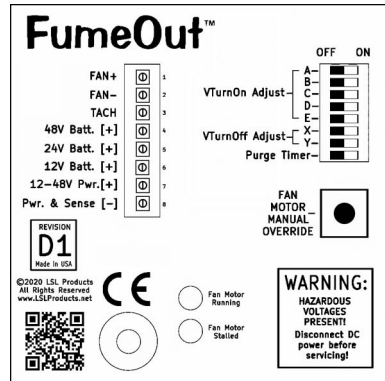

TO ENABLE THE PURGE TIMER: Move the Purge Timer DIP switch to its ON position. When enabled, the Purge Timer runs a cycle that turns the fan on for approximately 5 minutes every 24 hours whenever the battery voltage is below the Controller's programmed turn-on setting. A cycle is canceled if the battery voltage rises enough to turn on the fan, after which a new 24 hour cycle is started as soon as battery voltage drops enough to turn off the fan.

MOTOR STALLED Alarm: The fan motor speed is monitored whenever the fan is running - If it drops to nearly zero, the alarm beeper sounds, and the red **Fan Motor Stalled** LED blinks. This alarm is canceled whenever the battery voltage drops below the current Turn-Off Voltage setting.

BATTERY DISCONNECTED Alarm: The voltage at the 12, 24 and 48 volt Battery Sense [+] terminals is monitored all the time - If no voltage more than than 0.2 volts per cell is measured from at least one of these 3 terminals, the alarm beeper repeatedly sounds 3 short beeps until the fault is corrected.

SPECIFICATIONS

Absolute Min. / Max. Supply Voltage: 8.0 / 100.0 VDC

Nominal Battery Voltage:

12 volt / 6 cell battery bank:	9 to 16 VDC
24 volt / 12 cell battery bank:	18 to 32 VDC
48 volt / 24 cell battery bank:	36 to 64 VDC

Current Consumption:

Fan Motor Off:	5 mA typ. @ 12.8V
	3 mA typ. @ 25.6V
	2 mA typ. @ 51.2V
Fan Motor On:	220 mA typ. @ 12.8V
	110 mA typ. @ 25.6V
	55 mA typ. @ 51.2V

Turn-On (Von) Adjustment Range: 2.20 - 2.46 Volts/Cell
± 1% In 32 Increments

Turn-Off Settings: (Von - 0.033) Volts/Cell
(Von - 0.066) Volts/Cell
(Von - 0.133) Volts/Cell

Purge Timer Duration & Interval: 5 Minutes Every
24 Hours ± 10%

Operating Temperature Range: +20° to +125° F.

Air Flow: 52 CFM (free-air)

Noise Level (motor on): 27 dBA @ 36"

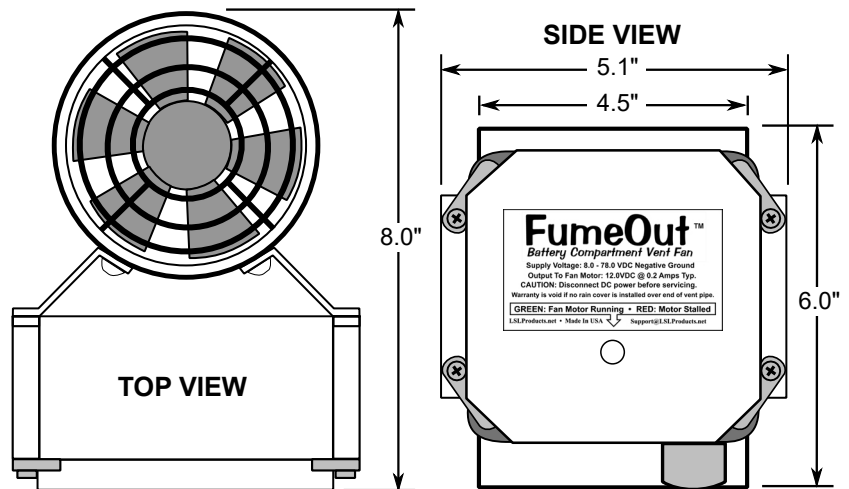

(Note: Rubber Drain Couplers Not Shown.)

This product has a ONE YEAR warranty against defects. For service or technical support, please email us at Support@LSLProducts.net.

LSL Products • P.O. Box 681072 • San Antonio, TX 78268 • www.LSLProducts.net • Email: Support@LSLProducts.net

6-1/4" VENT PIPE CUTTING TEMPLATE

Mechanical Installation

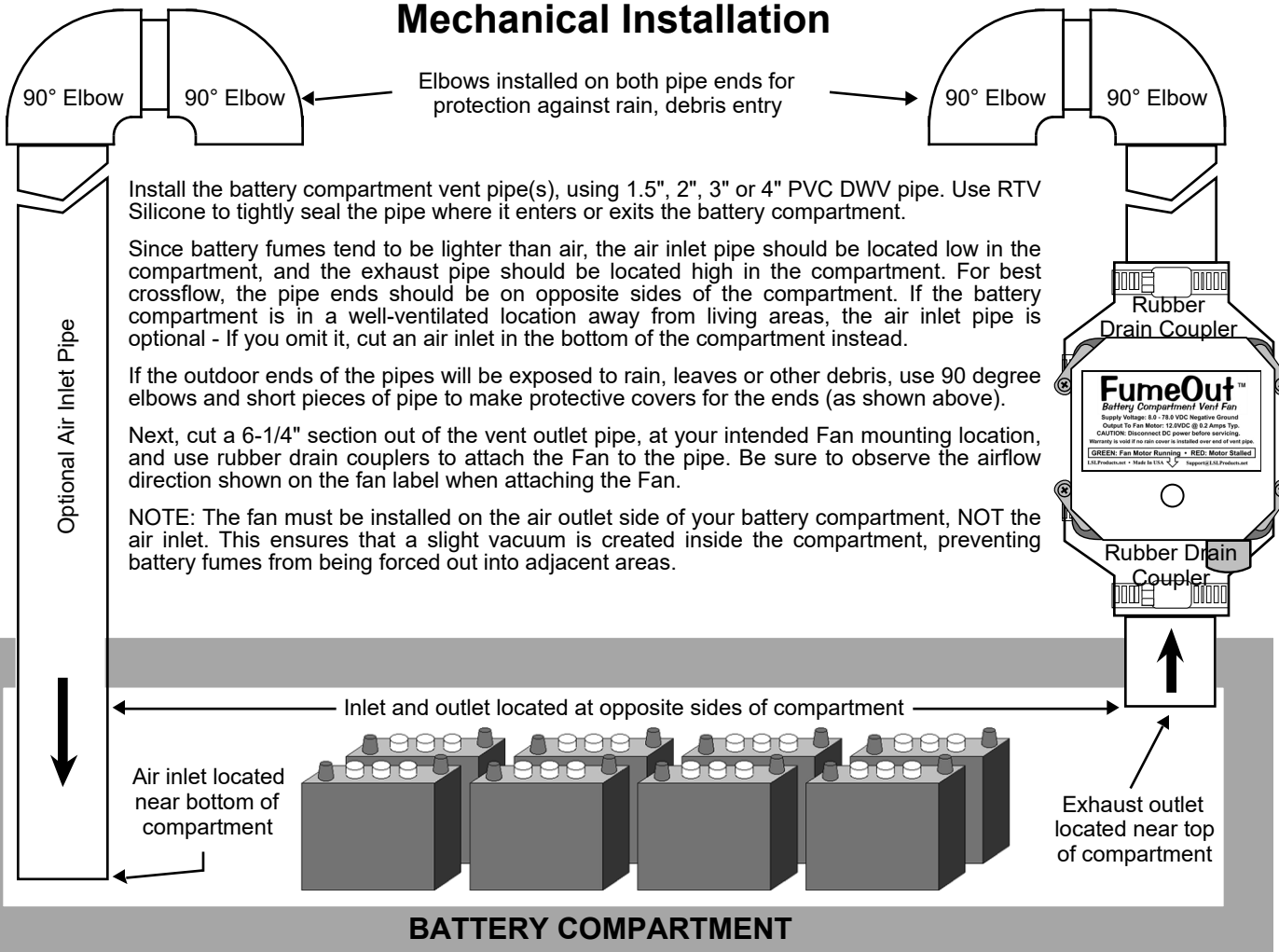

Electrical Installation

(24 Volt battery bank shown - 12V and 48V banks are similar)

Route three 20-16 gauge wires from your battery compartment through 1/2" conduit to inside the fan's weatherproof enclosure, and connect them to the fan circuit board:

1. Connect the wire for the negative terminal of your battery bank to the **Pwr. & Sense [-]** terminal (terminal 8).
2. Connect a voltage sense wire for the positive terminal of your battery bank to either the **48V Batt. [+]**, **24V Batt. [+]**, or **12V Batt. [+]** terminals (terminals 4, 5, or 6). Use which ever terminal corresponds to the nominal voltage of your particular battery bank (a 24 volt bank is shown in this particular example).
3. Connect a power-carrying wire for the positive terminal of your battery bank to the **12-48V Pwr. [+]** terminal (terminal 7).

Next, connect the other end of these same 3 wires to your battery bank:

1. Connect the voltage-sensing + wire to one of the included circuit breakers, connect the power-carrying + wire to the other circuit breaker, and then connect both circuit breakers to the positive post on your battery bank*.
2. Connect the negative wire to the negative post on your battery bank.

***CIRCUIT BREAKER DETAILS:** Strip approx. 1/4" off the end of a wire from the fan, twist any frayed wire strands together, and insert it into one hole in a Circuit Breaker. Strip and insert another short length of wire in the other hole, and connect its other end to the battery [+].

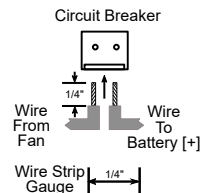

NOTES: (1.) Keep wire length between the circuit breakers and the battery [+]. post as short as possible.
(2.) Separate power-carrying and voltage-sensing wires are used to avoid measurement errors due to voltage drop when the fan turns on. Use of a single wire for both connections is NOT recommended.

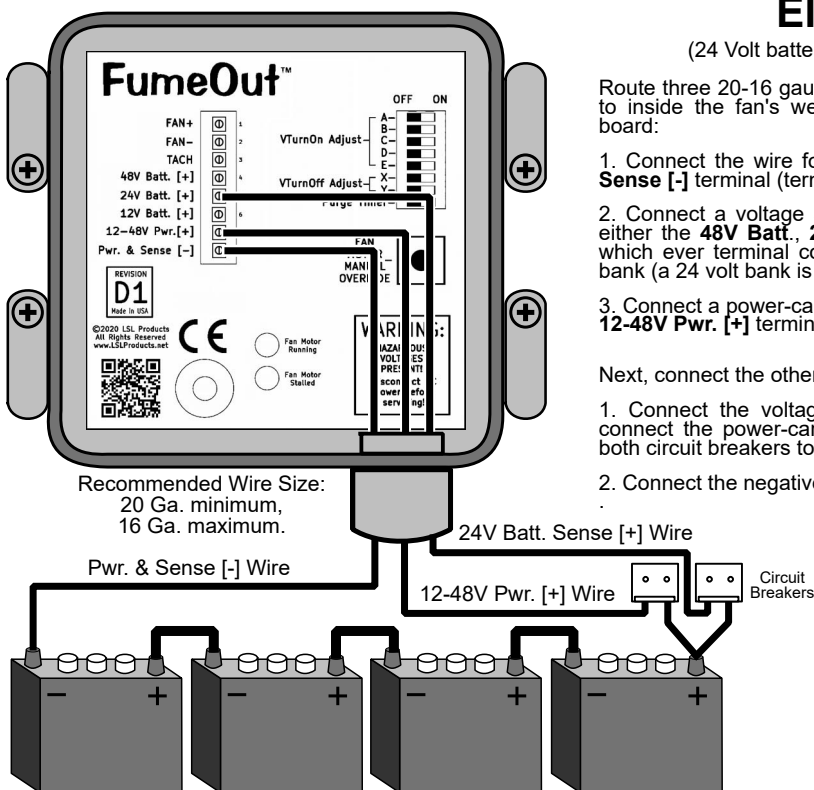

CAUTION: Use care when working around batteries - Risk of electric shock, chemical burns, explosive gasses!